

Alpha 86

L a b e l A p p l i c a t o r s



Weber's Alpha 86 combines speed with precision to create a line of widely versatile pre-printed label applicators. Pressure-sensitive labels are applied in-line using the reliable wipe-on method, where a label automatically is peeled from its liner, and then gently but firmly is affixed to the carton or product.

The system applies labels up to 4.72" wide and 39.0" long at speeds up to 80 or 200 feet per minute, with ± 0.03 " placement accuracy. The higher-speed version is also offered in a model that accommodates labels up to 5.9" wide, with special configurations available for even wider labels.

The Alpha 86 can be oriented to apply labels on the tops, sides, or bottoms of products. To add to the system's versatility, it is available in either a left- or right-hand version.

The unit's cast aluminum construction provides the durability needed to withstand harsh industrial environments. Plus, the stepper motor allows for labeling accuracy that eliminates common errors such as skipping a product or double labeling.

Versatile options for the Alpha 86 include various sensors, power unwind/rewind, and an adjustable mounting stand. Weber also offers a wide selection of standard and custom-designed labels to meet virtually any labeling need.

KEY FEATURES

- Applies pressure-sensitive labels at rates up to 200 feet per minute
- Wipe-on application of labels up to 5.9"W X 39.0"L
- Consistent placement accuracy of ± 0.03 "
- Symmetrical design for right- or left-hand operation

Geset
— A Weber® Company

Weber
LABELING & CODING SOLUTIONS

Alpha 86

Label Applicator Specifications

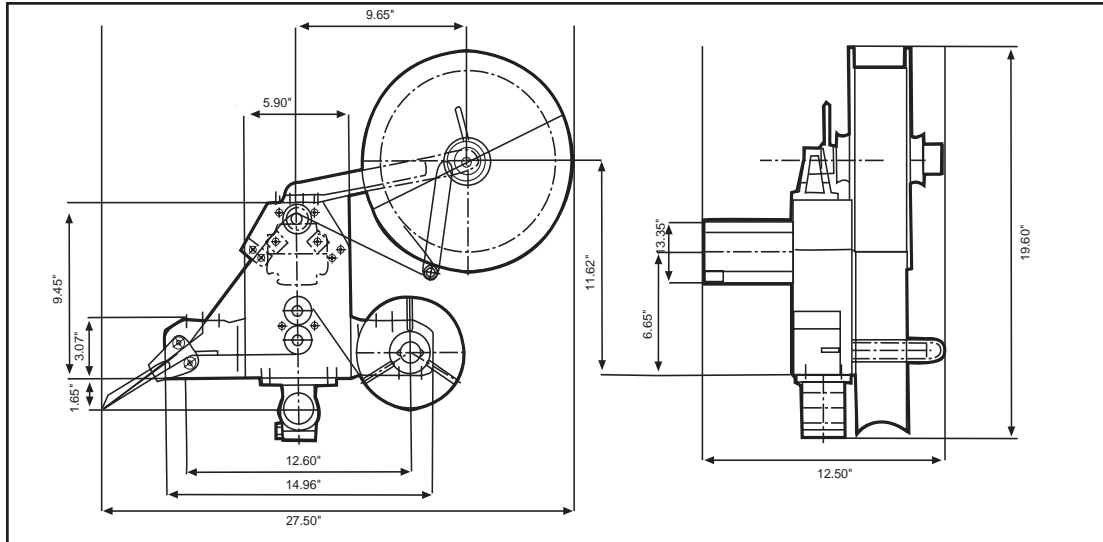

Dimensions

27.5"L x 12.5"W x 19.6"H
(70cm x 32cm x 50cm)

Weight

50 lbs (22kg)

Electrical

110/230 volts; 50/60 Hz

Product Sensing

Photoelectric

Label Roll Size

12.0" O.D. (301mm) wound on 3.0" (76mm)
I.D. core

Label Styling Requirement

Die-cut, waste removed, with minimum of 0.125" (3mm) separation between labels in the running direction

Label Placement Accuracy

Label placement to $\pm 0.03"$ (0.8mm) when labels are produced to specifications and product is controlled

Standard Label Sizes*

Minimum width: 0.75" (19mm)
Maximum width: 5.9" (150mm)
Minimum length: 0.75" (19mm)
Maximum length: 39.0" (991mm)

Labeling Speed

Up to 80 (24m) or 200 (61m) feet per minute, depending on model

Options

Adjustable stand
Low label and web break sensor
Power unwind/rewind

*Wider sizes available

Weber Marking Systems, Inc.

World Headquarters

Weber Marking Systems, Inc.
711 W. Algonquin Road
Arlington Heights, IL 60005-4457
Phone: 847.364.8500
Fax: 847.364.8575
E-Mail: info@webermarking.com
www.webermarking.com

Canada

Weber Marking Systems of Canada
6180 Danville Road
Mississauga, Ontario L5T 2H7
Phone: 905.564.6881
Fax: 905.564.6886
E-Mail: info@webermarking.ca
www.webermarking.ca

United Kingdom

Weber Marking Systems UK
Macmerry Industrial Estate
Tranent, East Lothian EH33 1HD
Scotland
Phone: 44.18.756.11111
Fax: 44.18.756.13310
E-Mail: sales@weber.co.uk
www.weber.co.uk

Germany

Weber Marking Systems GmbH
Postfach/Box 0154
Honnefer Str. 41
D-53572 Unkel/Rhein
Phone: 49.2224.77080
Fax: 49.2224.770820
E-Mail: info@webermarking.de
www.webermarking.de

Thailand

Weber Marking Systems (Thailand) Ltd.
10/106 Moo 7 Soi Wat Hua Krabue
Bangkhuntien Road
Takham, Bangkhuntien, Bangkok
10150, Thailand
Phone: 66.2.897.4871
Fax: 66.2.897.4272
E-Mail: sales@weber.co.th

Belgium

Weber Marking Systems NV/SA
Loten 1
B-4700 Eupen - Belgium
Phone: 32.87.593979
Fax: 32.87.593970
E-Mail: mail@webermarking.be

Denmark

Weber Marking Systems A/S
Nordkrogen 7
DK-7300 Jelling, Denmark
Phone: 45.75.87.26.00
Fax: 45.75.87.26.10
E-Mail: sales@norconweber.dk

Netherlands

Weber Etiketten BV
Steurstraat19,
1317 NZ Almere, Nederland
Phone: 036.5345254
Fax: 036.5345659
E-Mail: etiketten@weber.nl
www.weber.nl

Ireland

Weber Marking Systems Ireland
61 Irish Street, Enniscorthy
County Wexford, Ireland
Phone: 353.54.33.778
Fax: 353.54.33.284
E-Mail: weberireland@eircom.net

Turkey

Weber Etiket ve Etiketleme Sistemleri
San ve Tic Ltd., Sti
Nazmi Akbaci Tocaret No. 205-207 AK
TR-80670 Maslak Istanbul, Turkey
Phone: 90.212.285.9400
Fax: 90.212.285.0574
E-Mail: eta@turk.net

Geset
— A Weber® Company

Weber
LABELING & CODING SOLUTIONS

